

111 NAVY



emeco

FIRST LET'S MAKE THINGS THAT LAST.

The Emeco 1006 Navy Chair was first commissioned in the 1940s by the U.S. Navy for use on warships – the contract even specified that it had to be able to withstand torpedo blasts. Today our chairs are still made in the U.S.A., of 80% recycled aluminum, and are made by hand, by Emeco craftsmen using the original 77 step process. The world's best architects and designers collaborate with us to design chairs that are built and guaranteed to last a lifetime.

As we apply what we've practiced in the past, we are looking toward the future. We are on a mission to make a positive impact on the environment. Our goals are to use waste material in our products, use as little energy as possible in our manufacturing, generate a minimum of waste in the process, and build strong, durable, beautiful chairs that last through generations. We've been on the same mission since 1944 and we will continue to search for new ways to recover and utilize discarded materials and make products that last.

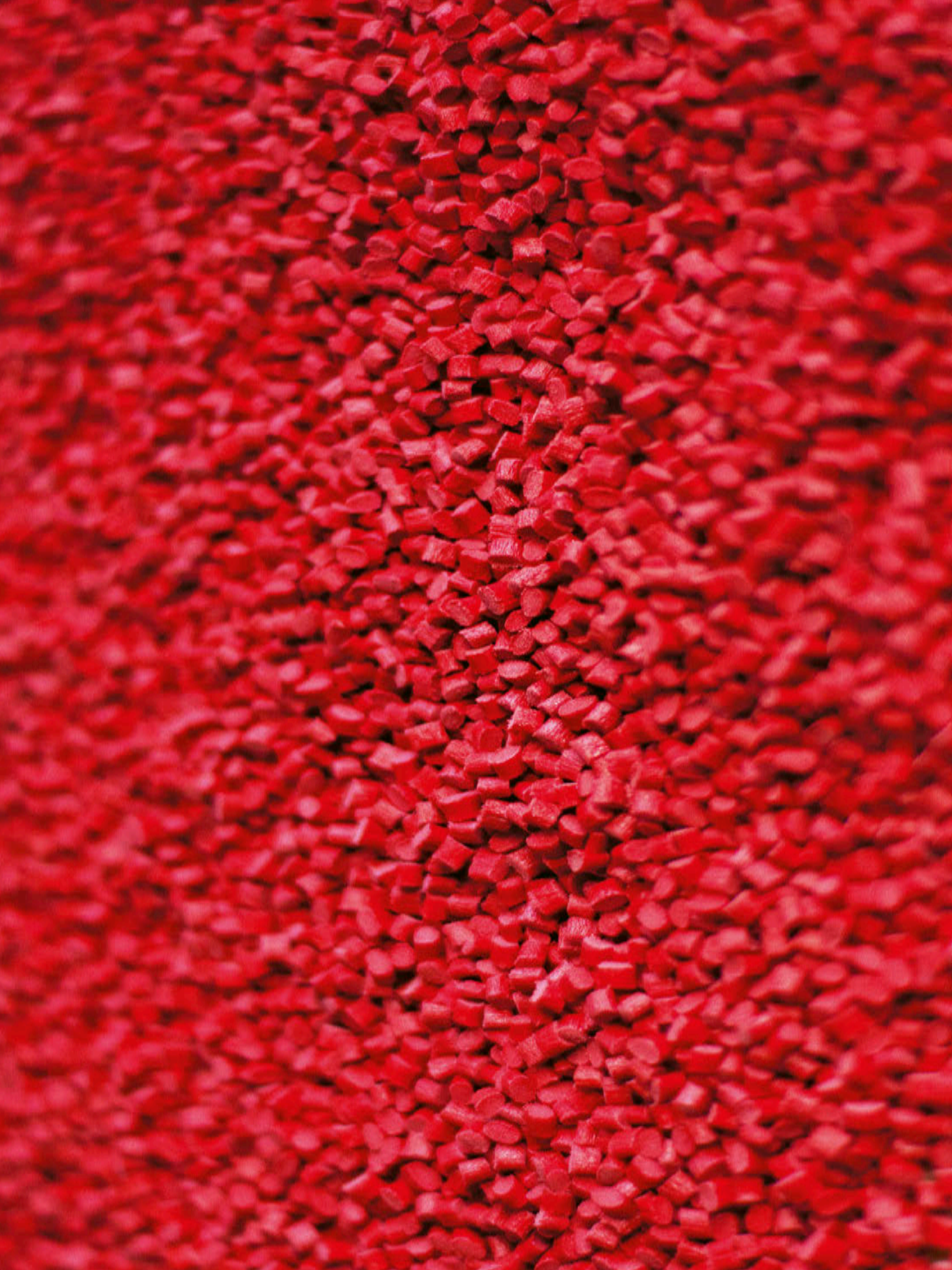

GOOD OLD-FASHIONED AMERICAN INNOVATION.

We get the most out of the material we use. For years, that material was recycled aluminum. We developed a way to work with it to make products of extraordinary strength, durability and beauty.

In 2006 Coca-Cola approached Emeco with a problem: Billions of plastic bottles were being sent to the landfill every year. We saw an opportunity. By up-cycling, we transformed the waste into a new material. It took years to turn PET into something structurally sound enough to sit on. But it was well worth the time. The 111 Navy chairs and stools are strong, durable, and have a deep beauty that people love when they touch it. And they're made from recycled plastic bottles. In fact, we originally called it the 111 Navy Chair because every chair we make takes 111 plastic bottles out of the landfill.

Plastic. Our goal is to keep it out of the landfill and turn it into something people will keep.



WASTEFUL
TURNED
INTO
HOPEFUL.



"I was excited about the impact of using the rPET from millions of bottles that are discarded each year. With the 111 Navy Chair, we keep over 3 million bottles out of landfills every year. Now, with the new 111 Navy stools, our goal is to save 10 million bottles from the landfill every year. That's making a difference." – *Gregg Buchbinder, Emeco*

111 NAVY COLLECTION by EMECO

111 Navy is a story of innovation. The 111 Navy Chair is now joined by stools in two heights; kitchen counter and bar height, each made of 150 recycled bottles. Like the chair, these one-piece stools are an engineering success – made to stand up to heavy use, and made in the USA.



111 Navy Chairs in White
Avenues The World School, NYC
By: Perkins/Eastman and Bonetti/Kozerski.
Photo: Luca Piottelli

A close-up photograph of the backrest of a dark grey Emeco chair. The backrest features a curved, ribbed design with four vertical slats. A light-colored, curved cushion is visible between the slats. The brand name 'emeco' is printed in a lowercase, sans-serif font on the lower part of the backrest.

emeco



111 Navy Chair in Persimmon
Basecamp Hotel, South Lake Tahoe, USA
By: Elaine Cotter. Photo: Eva Kolenko



111 Navy Chairs in Charcoal
Google, London
By: Penson. Photo: David Barbour



111 Navy Counter Stools in Beach
Photo: Eric Petschek

111 NAVY Collection

Registered under US trademark reg. No 2511360.

111Navy Chair

111 Navy Counter Stool

111 Navy Barstool

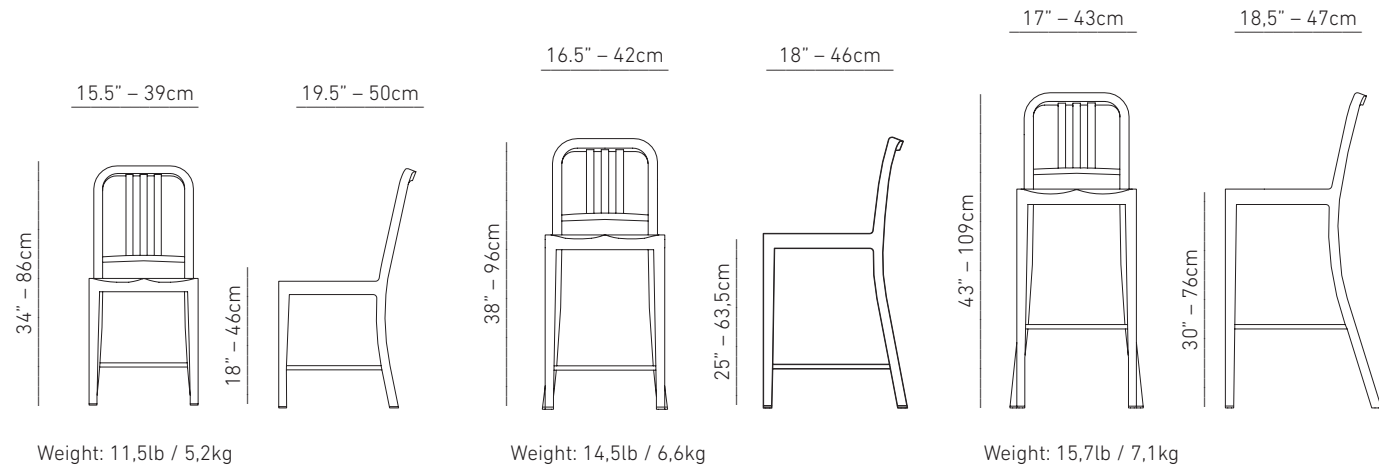

MATERIAL

Material	Chair: 75% Recycled PET (at least 111 recycled bottles) Counter Stool/Barstool: 65% Recycled PET (at least 150 recycled bottles)
Warranty	5 Year Warranty
Outdoor Use	3 Year Warranty
Strength & Stability Test	ANSI/BIFMA X5.1
Fire Retardant	Certified Acc. to CAL133
VOC Emissions Test	ANSI/BIFMA M7.1



www.emeco.net

805 WEST ELM AVENUE, HANOVER PENNSYLVANIA 17331 USA, T: +1 717 637 5951, F: +1 717 633 6018, E: INFO@EMECO.NET